

OPERATION & SAFETY INSTRUCTIONS

ROUND AIR FLOW AMPLIFIERS

Models 901 series, 902, 903, 904, 909A
(Includes all BSP versions of models listed above)



IMPORTANT

Please read all instructions BEFORE attempting to use this product



ITW Air Management

10125 Carver Road, Cincinnati, OH 45242
Phone: 513-891-7474 • Fax: 513-891-4092
Toll Free: 800-441-7475
www.vortec.com • techsupport@vortec.com

GENERAL SAFETY CONSIDERATIONS

WARNING: COMPRESSED AIR COULD CAUSE DEATH, BLINDNESS OR INJURY

1. Do not operate air flow amplifiers at compressed air pressures above 150 psig (10.3 Bar).
2. Do not operate air flow amplifiers at line temperatures above 110°F (43°C).
3. Avoid direct contact with compressed air.
4. Do not direct compressed air at any person.
5. When using compressed air, wear safety glasses with side shields.

Introduction

An air flow amplifier uses a small amount of compressed air to move a much larger air volume. Amplification ratios may meet or exceed 20:1. For more details on airflow of a specific unit, visit www.vortec.com, or contact your local distributor or Vortec.

Compressed Air Supply

The compressed air supply must be filtered to remove water and dirt using a 5 micron or smaller filter. Failure to use a filter may cause clogging of the compressed air paths inside the Vortec product. Filter recommendations are given in Table 1.

Filter elements must be changed on a regular basis. Frequency of change is determined by the condition of the compressed air supply. Filters should be installed in the compressed air supply line as close as possible to the Vortec product.

The appropriate size of the compressed air supply line should be selected to ensure optimal performance of the Vortec product. Please refer to Table 2 to determine what supply line size is recommended for your application. Contact Vortec at 1-800-441-7475 for further assistance.

Operation

In order to vary the volume of airflow from the air flow amplifier, an appropriately sized pressure regulator can be used to control the compressed air pressure, (less pressure = less airflow). (Pressure regulator recommendations are given in Table 1.)

The output airflow volume can also be adjusted by varying the internal air gap. For models with shims (901A, 901BA, 901DA, 901HA, 902, 903, 904), this is accomplished by adding or removing gap shims (see Table 1). In adjustable model 909A, this can be accomplished by rotating the outlet barrel (counter-clockwise will increase airflow, clockwise will decrease airflow).

Installation and Maintenance

Air flow amplifiers can be installed by directly plumbing to the appropriately-sized, hard piped, compressed air source that does not exceed 150 psig (10.3 Bar), see Table 2.

When using air flow amplifiers for ducting fumes or smoke, the duct must be sized, and routed to prevent back pressure totaling more than 2" of water column. Back pressure in ducted airflow will substantially affect performance.

It is critical to the performance of the air flow amplifier that the internal air passages remain clean. If the air flow amplifier's performance suddenly drops, carefully disassemble the unit and inspect for debris. If debris is found, it may be necessary to change your filter element. Clean the debris from the unit and reassemble. Use caution during reassembly to ensure that the shim (where applicable) remains centered and does not become lodged in the air passage. For detailed instructions on cleaning or reassembly, contact your authorized distributor or Vortec.

Troubleshooting

Insufficient airflow may be caused by the following:

1. Undersized compressed air line size.
2. Compressed air pressure too low.
3. Partial or complete blockage of internal air path, due to dirt. See Maintenance section for cleaning instructions; and Compressed Air Supply section for filter recommendations.
4. Insufficient compressed air volume.

If trouble persists, please contact Vortec at 1-800-441-7475.

Limited Warranty

Vortec compressed air products manufactured by ITW Air Management will be replaced or repaired if found to be defective due to manufacture defect within ten years from the date of invoice. Refer to our website www.vortec.com for full warranty details and limitations. ITW Air Management makes no specific warranty merchantability or warrant of fitness to a particular purpose.

Exploded Views

(Drawings shown below are not to scale)

Model 902

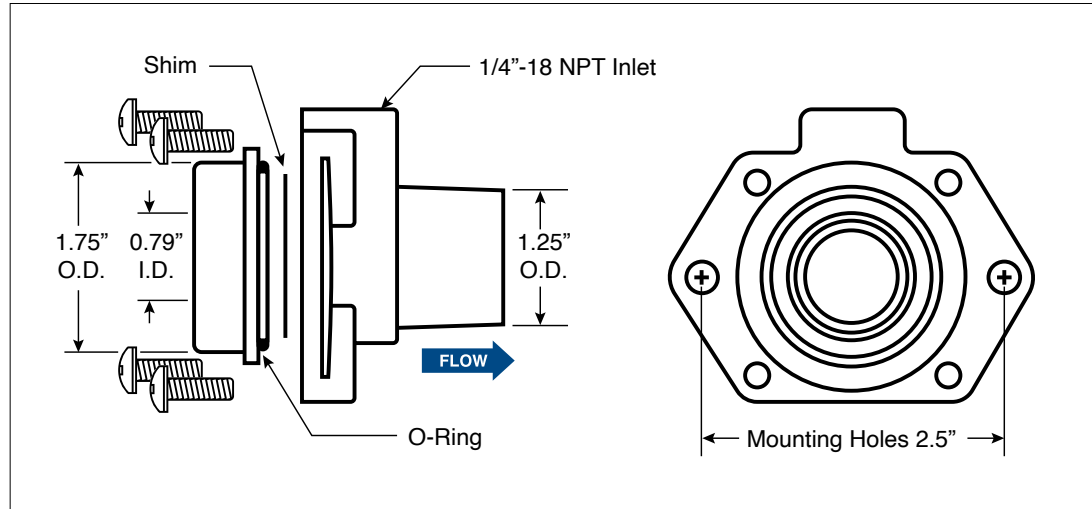

Model 903

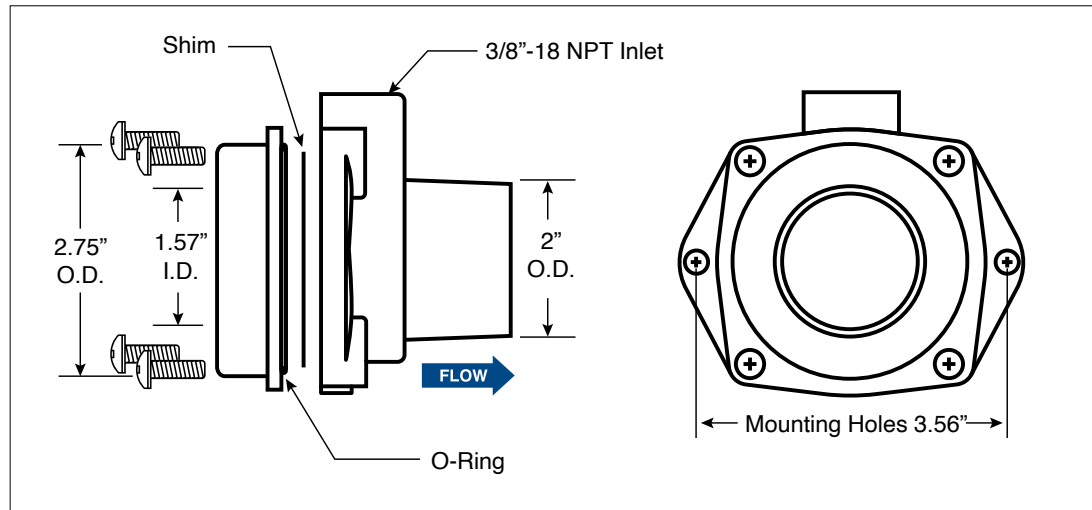

Model 904

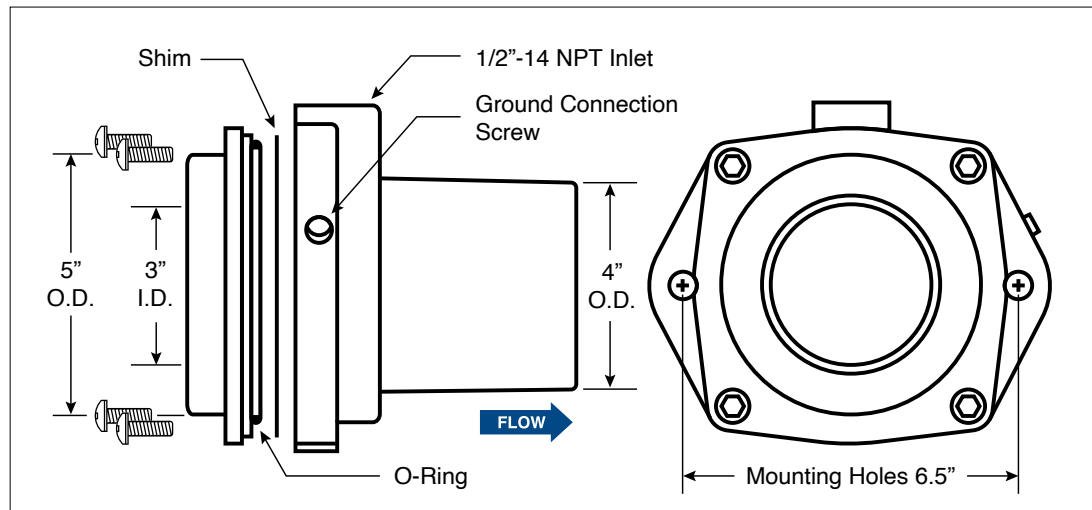

Table 1: Filter Recommendations

FILTER AND REPLACEMENT PART ITEM NUMBERS				
Vortec Model	5 micron Air Filter	Oil Removal Filter	Pressure Regulator	.002" or .003" shims
901 series	701S-24A	701S-48	208R	901-002, 901-003
902A	701S-24A	701S-48	208R	-
902	701S-24A	701S-48	208R	902-002, 902-003
903	701S-36A	701S-48	208RX	903-002, 903-003
904	701S-40A	701S-54	208RX	904-002, 904-003

Table 2: Determining Compressed Air Line Size

1. Calculate total product compressed air consumption (SCFM, SLPM).
2. Determine length of compressed air line required for connection to main supply.
3. Locate pipe length in left column and read to the right to find the compressed air requirements.
4. Locate pipe size at top of column.

MAXIMUM AIRFLOW (SCFM) THROUGH PIPE AT 5 PSIG PRESSURE DROP (100 PSIG AND 70°F)									
Pipe Length (Feet)	Pipe Size (Nominal) - Schedule 40								
	1/4	3/8	1/2	3/4	1	1-1/4	1-1/2	2	2-1/2
10	29	65	120	254	480	978	1483	2863	4536
20	21	46	85	180	340	692	1049	2024	3208
30	17	37	70	147	277	565	856	1653	2619
40	15	32	60	127	240	489	792	1431	2268
50	13	29	54	114	215	437	663	1280	2029
60	12	26	49	104	196	399	606	1169	1852
70	11	25	46	96	181	370	561	1082	1715
80	10	23	43	90	170	346	524	1012	1604
90	10	22	40	85	160	326	494	954	1512
100	9	21	38	80	152	309	469	905	1435

MAXIMUM AIRFLOW (SLPM) THROUGH PIPE AT 0.3 BAR PRESSURE DROP (6.9 BAR AND 21°C)									
Pipe Length (Meters)	Pipe Size (Nominal) - Schedule 40								
	1/4	3/8	1/2	3/4	1	1-1/4	1-1/2	2	2-1/2
3	821	1840	3396	7188	13584	27677	42117	81023	128369
6	594	1302	2406	5094	9622	19584	29687	57279	90786
9	481	1047	1981	4160	7839	15990	24225	46780	74188
12	425	906	1698	3594	6792	13839	20999	40497	64184
15	368	821	1528	3226	6085	12367	18763	36224	57421
18	340	736	1387	2943	5547	11292	17150	33083	52412
21	311	708	1302	2717	5122	10471	15877	30621	48535
24	283	651	1217	2547	4811	9792	14829	28640	45393
27	269	623	1132	2406	4528	9226	13980	26998	42790
31	255	594	1075	2264	4302	8745	13273	25612	40611

Rubber hose maximum airflow rating: 1/2" I.D. rubber hose = 3/8" pipe; 3/4" I.D. rubber hose = 1/2" pipe